



C16A...

Self-restoring pendulum load cell

Special features

- Self-restoring function
- Maximum capacities: 20 t ... 100 t
- Simple installation
- Rust-resistant materials, laser-welded, IP68/IP69K
- Legal for trade
 - up to 5000 d (OIML R60)
 - up to 10000 d (NTEP class III LM)
- Optimized for parallel connection by off-center load compensation
- Meets EMC requirements as per EN 45 501:2015
- Ex protection versions per IECEx and ATEX (optional)

Cable assignment

Cable assignment (6-wire configuration):

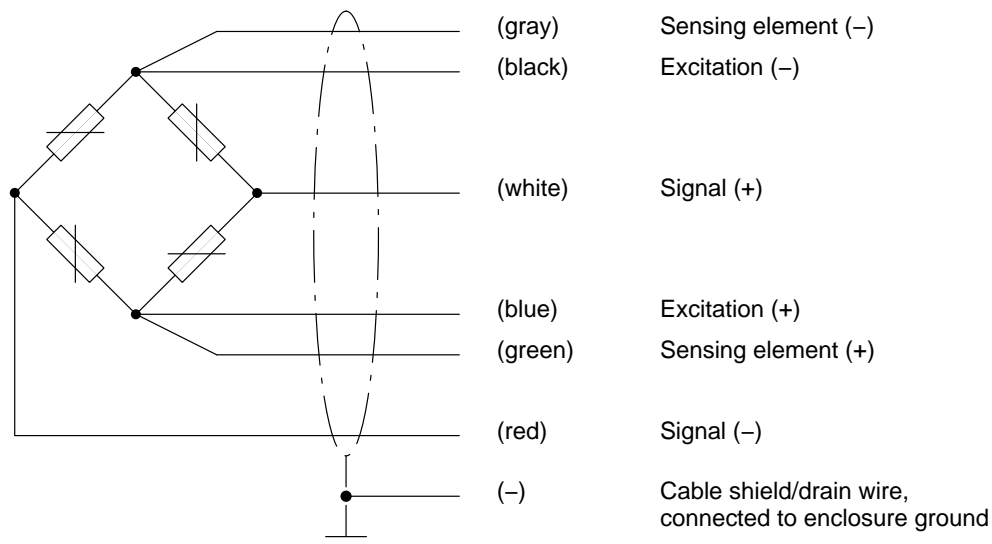

Specifications

Type		C16A D1					C16A C3					C16A C4			
Maximum capacity (E_{max})		20 t	30 t	40 t	60 t	100 t	20 t	30 t	40 t	60 t	100 t	20 t	30 t	40 t	60 t
Accuracy class according to OIML R60		D1 (0.0330 %)					C3 (0.0170 %)					C4			
Number of load cell verification intervals (n_{LC})		1000 (10000 NTEP III LM)					3000					4000			
Minimum load cell verification interval (v_{min})	% of E_{max}	0.0200 (0.0068 NTEP III LM)					0.0100	0.0083	0.0167	[Option: 0.0050]		0.0100	0.0083		
Nominal (rated) sensitivity (C_n)	mV/V	2													
Sensitivity tolerance ¹⁾	%	± 0.5 ¹⁾													
Temperature coefficient of sensitivity (TC_S) ²⁾	% of $C_n/1$	± 0.0250 ²⁾					± 0.0080 ²⁾					± 0.0070 ²⁾			
Temperature coefficient of zero signal (TC_0)	0 K	± 0.0285					± 0.0140	± 0.0116	± 0.0234	± 0.0140	± 0.0116				
Relative reversibility error (d_{hy}) ²⁾	% of C_n	± 0.0330 ²⁾					± 0.0170 ²⁾					± 0.0140			
Non-linearity (d_{lin}) ²⁾		± 0.0300 ²⁾					± 0.0180 ²⁾					± 0.0120			
Creep upon loading (d_{cr}) over 30 min.		± 0.0330					± 0.0167					± 0.0125			
Minimum dead load output return (DR), 30 min.		± 0.0330 (± 0.0150 NTEP III LM)					± 0.0167					± 0.0125			
Repeatability error (max. change in load cell output for repeated loading)		± 0.005													
Input resistance (R_{LC}) (black-blue)	Ω	700 ± 20													
Output resistance (R_0) ¹⁾ (red-white)		706 ± 3.5 ¹⁾													
Reference excitation voltage (U_{ref})	V	5													
Nominal (rated) range of the excitation voltage (B_U)		0.5 ... 12													
Insulation resistance (R_{is})	G Ω	> 5													
Nominal (rated) range of the ambient temperature (B_T)	$^{\circ}C$	-10 ... +40													
Operating temperature range (B_{tu})		-50 ... +70													
Storage temperature range (B_{tl})		-50 ... +85													
Limit load (E_L)	% of E_{max}	150													
Breaking load (E_d)		> 350													
Relative permissible oscillatory stress (F_{srel}) (oscillation bandwidth as per DIN 50100 with 10,000,000 load changes)		70													
Maximum capacity (E_{max})		20 t	30 t	40 t					100 t						
Deflection at E_{max} (s_{nom}), approx.	mm	0.65	0.75	0.85					1.57						
Weight (G) with cable, approx.	kg	2.1	2.3	2.9					8						
Degree of protection per EN60529 (IEC529)		IP68 (test conditions 1 m water column/100 h) IP69 K (water at high pressure, steam jet cleaning)													
Material: Measuring body + housing Cable entry Seal Cable sheath		stainless steel ³⁾ stainless steel ⁴⁾ (E_{max} 100 t: nickel-plated brass) Viton [®] (E_{max} 100 t: silicone) thermoplastic elastomer													

¹⁾ Because of the off-center load compensation, the sensitivity and output resistance are matched in such a way that when there is eccentric loading, the scale display is within the permissible error limits.

²⁾ The values for non-linearity (d_{lin}), relative reversibility error (d_{hy}) and temperature coefficient of sensitivity (TC_S) are recommended values. The sum of these values is within the cumulated error limit for $p_{LC} = 0.7$ according to OIML R60 or NTEP.

³⁾ as per EN 10088-1

Options for C16A

- **Ex protection versions per IECEx and ATEX:**
AI1/21 IECEx+ATEX zone 1/21 + FM intrinsically safe, II 2G Ex ia IIC T6/T4 Gb, II 2D Ex ia IIIC T125°C Db*
AI2/21IECEx+ATEX zone 2/21 not intrinsically safe, II 3G Ex nA IIC T6/T4 Gc, II 2D Ex tb IIIC T125°C Db***
 - * with EU type examination certificate (BVS13ATEX E 108 X) and IECEx Certificate of Conformity (IECEx BVS 13.0109 X)
 - ** IECEx zone 2/21 includes option ATEX2/22 and also offers the additional customer benefit of usage with conductive dust as well.
- **Ex protection in "flameproof enclosure Ex d" version, see separate data sheet**
- **Overvoltage protection**
- **$v_{\min} = 0.0050\%$ (Y=20000)**
- **Accuracy class C5 (OIML) on request**
- **Cable length 20 m ($E_{\max} = 20 \text{ t} + 30 \text{ t}$) / • Cable length 40 m ($E_{\max} = 20 \text{ t} \dots 100 \text{ t}$)**
- **20 m cable with braided wire ($E_{\max} = 20 \text{ t} \dots 100 \text{ t}$)**

Dimensions and fittings for maximum capacities 20 t ...60 t

Dimensions in mm (1 mm = 0.03937 inches)

Installation variant 1:

C16.../≤60 t + C16/ZOU44A (max. load per load cell = 40 t)

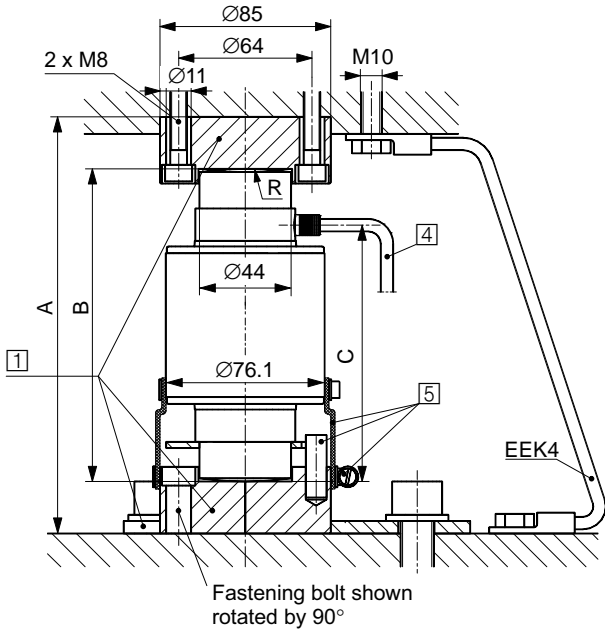

View from above

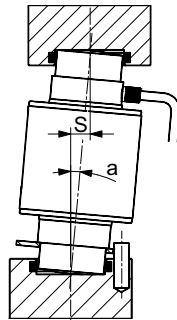
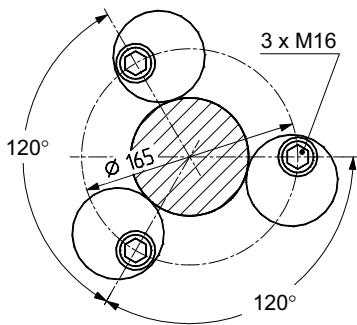

Installation variant 2:

C16.../≤60 t + EPO3/50 t + C16/EPU44A

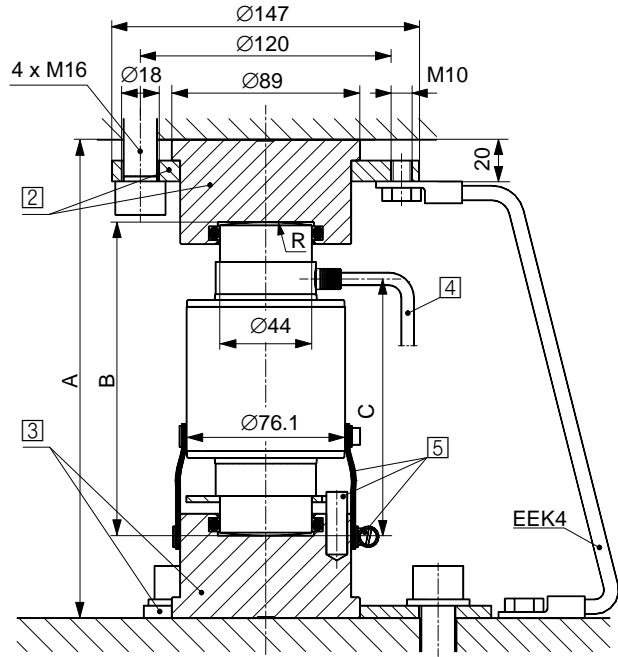

- 1 C16/ZOU44A
- 2 EPO3/50 t
- 3 C16/EPU44A
- 4 **Cable length (standard):**
20 t + 30 t = 12 m;
40 t + 60 t = 20 m
- 5 Dowel pin $\varnothing 10 \times 30$ (rotation stop),
sealing sleeve and hose clamp included in
load cell scope of supply

Cable:
 $\varnothing 5.4$ mm (standard)
 $\varnothing 6.4$ mm with braided wire option (20R)

Installation variant 1	E_{max} C16...	Thrust pieces above + below (1 set = 2 pieces)		A	B	C	R Ball	$a_{max}^{2)}$	$S_{max}^{3)}$	$F_R^{4)}$ (% of applied load)	
										at S_{max}	at $S = 1$ mm
	20 t	C16/ZOU44A 1)		200	150	123	130	5°	13	6.4	0.49
	30 t			200	150	123	160	5°	13	9.9	0.76
	40 t			200	150	123	180	5°	13	12.2	0.94
	60 t			260	210	157	220	3°	11	5.7	0.52
Installation variant 2	E_{max} C16...	Thrust pieces		A	B	C	R Ball	$a_{max}^{2)}$	$S_{max}^{3)}$	$F_R^{4)}$ (% of applied load)	
		above	below							at S_{max}	at $S = 1$ mm
	20 t	EPO3/50 t	C16/EPU44A	229	150	123	130	5°	13	6.4	0.49
	30 t			229	150	123	160	5°	13	9.9	0.76
	40 t			229	150	123	180	5°	13	12.2	0.94
	60 t			289	210	157	220	3°	11	5.7	0.52

1) Max. load: 40 t
2) Max. perm. misalignment

3) Max. permissible lateral displacement of load application
4) Restoring force

Dimensions and fittings for 100 t maximum capacity

C16.../100 t + EPO3/100 t + C16/EPU64

Dimensions in mm (1 mm = 0.03937 inches)

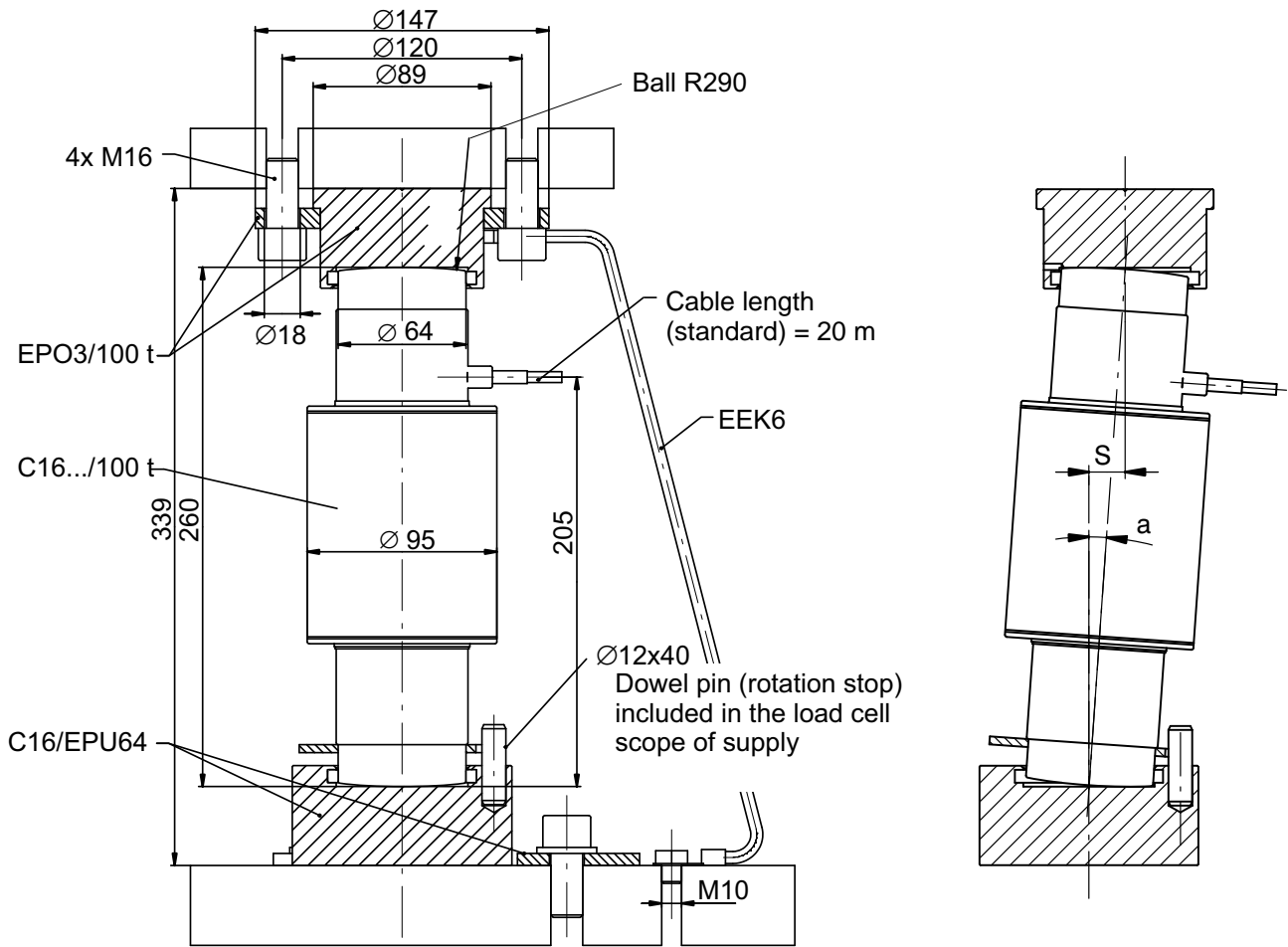

View from above

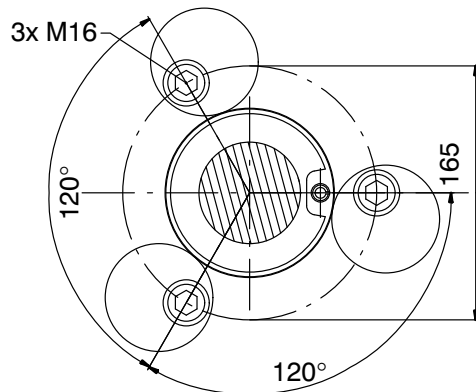

a_{\max} (max. perm. misalignment)	S_{\max} (max. permissible lateral displacement of load application)	F_R (restoring force, % of applied load)	
		at S_{\max}	at $S = 1 \text{ mm}$
4°	18	8.6	0.48

Other available maximum capacities: 200 t and 400 t (see separate data sheet)

Accessories (to be ordered separately)

Thrust pieces

Maximum capacities 20 t ... 60 t - Installation variant 1:

- **C16/ZOU44A** Thrust pieces (stainless) for above and below (1 set = 2 pieces), can be used with C16.../≤60 t up to a max. load per load cell of 40 t, incl. 3 eccentric discs

Maximum capacities 20 t ... 60 t - Installation variant 2:

- **EPO3/50 t** Thrust piece for above, incl. clamping ring
- **C16/EPU44A** Thrust piece for below, incl. 3 eccentric discs

Maximum capacity 100 t:

- **EPO3/100 t** Thrust piece for above, incl. clamping ring
- **C16/EPU64** Thrust piece for below, incl. 3 eccentric discs

Ground cable (copper), cross-section: 16 mm²

- **EEK4** for maximum capacities 20 t ... 60 t, length 400 mm, ordering number: 1-EEK4
- **EEK6** for maximum capacities 100 t + 200 t, length 600 mm, ordering number: 1-EEK6

Product numbers

C16A load cells			
Type	C16A(D1)	C16AC3	C16AC4
Accuracy class	D1 (OIML) / III LM (NTEP)	C3 (OIML)	C4 (OIML)
Comments	-	-	-
Maximum capacity	Ordering number	Ordering number	Ordering number
20 t	1-C16A2D1/20T-1	1-C16A3C3/20T-1	
30 t	1-C16A2D1/30T-1	1-C16A3C3/30T-1 1-C16A3C3/30T/L2-1*	1-C16A2C4/30T
40 t	1-C16A2D1/40T-1	1-C16A2C3/40T-1	1-C16A2C4/40T
60 t	1-C16A2D1/60T	1-C16A2C3/60T	1-C16A2C4/60T
100 t	1-C16A2D1/100T	1-C16A2C3/100T	
200 t	1-C16A2D1/200T		
400 t	1-C16A2D1/400T		

* With 20 m cable length and overvoltage protection

C16A load cells, optional versions

Ordering number
K-C16A2

Code	Option 1: Mechanical design
S	Standard

Code	Option 2: Accuracy class
D1	D1 (OIML)
C3	C3 (OIML) [only with option 3 = 20 / 30 / 40 / 60 / 100]
C4	C4 (OIML) [only with option 3 = 30 / 40 / 60]
C5	C4 (OIML) [only with option 3 = 30 / 40 / 60] (on request)

Code	Option 3: Maximum capacity
20	20 t [only with option 2 = D1 / C3]
30	30 t [only with option 2 = D1 / C3 / C4 / (C5 on request)]
40	40 t [only with option 2 = D1 / C3 / C4 / (C5 on request)]
60	60 t [only with option 2 = D1 / C3 / C4 / (C5 on request)]
100	100 t [only with option 2 = D1 / C3]
200	200 t [only with option 2 = D1 and option 6 = N]
400	400 t [only with option 2 = D1]

Code	Option 4: Explosion protection
N	no ATEX
AI1/21	IECEX + ATEX 1 + 21 and FM 
AI2/21	IECEX + ATEX zone 2 + 21

Code	Option 5: Cable length
S12	12 m (standard) [only with option 3 = 20 / 30]
S20	20 m (standard) [only with option 3 = 40 / 60 / 100 / 200]
20	20 m [only with option 3 = 20 / 30]
40	40 m
20R	20 m (braided wire) [only with option 3 = 20 / 30 / 40 / 60]

Code	Option 6: Overvoltage protection
N	none
L	With overvoltage protection

Code	Option 7: Other
N	none
Y	Y=20000 [only with option 2 = C3 + option 3 = 30/40/60]

K-C16A2 - S - [] - [] - [] - [] - [] - [] - [] - [] - [] - []

Subject to modifications.
All product descriptions are for general information
only. They are not to be understood as a guarantee
of quality or durability.

Hottinger Baldwin Messtechnik GmbH
Im Tiefen See 45 · 64293 Darmstadt · Germany
Tel. +49 6151 803-0 · Fax +49 6151 803-9100
E-mail: info@hbm.com · www.hbm.com

measure and predict with confidence

